



D O P P I A

The Story Behind >>



Opportunity Area >>





Experience/Emotion/Mood >>



The Design >>

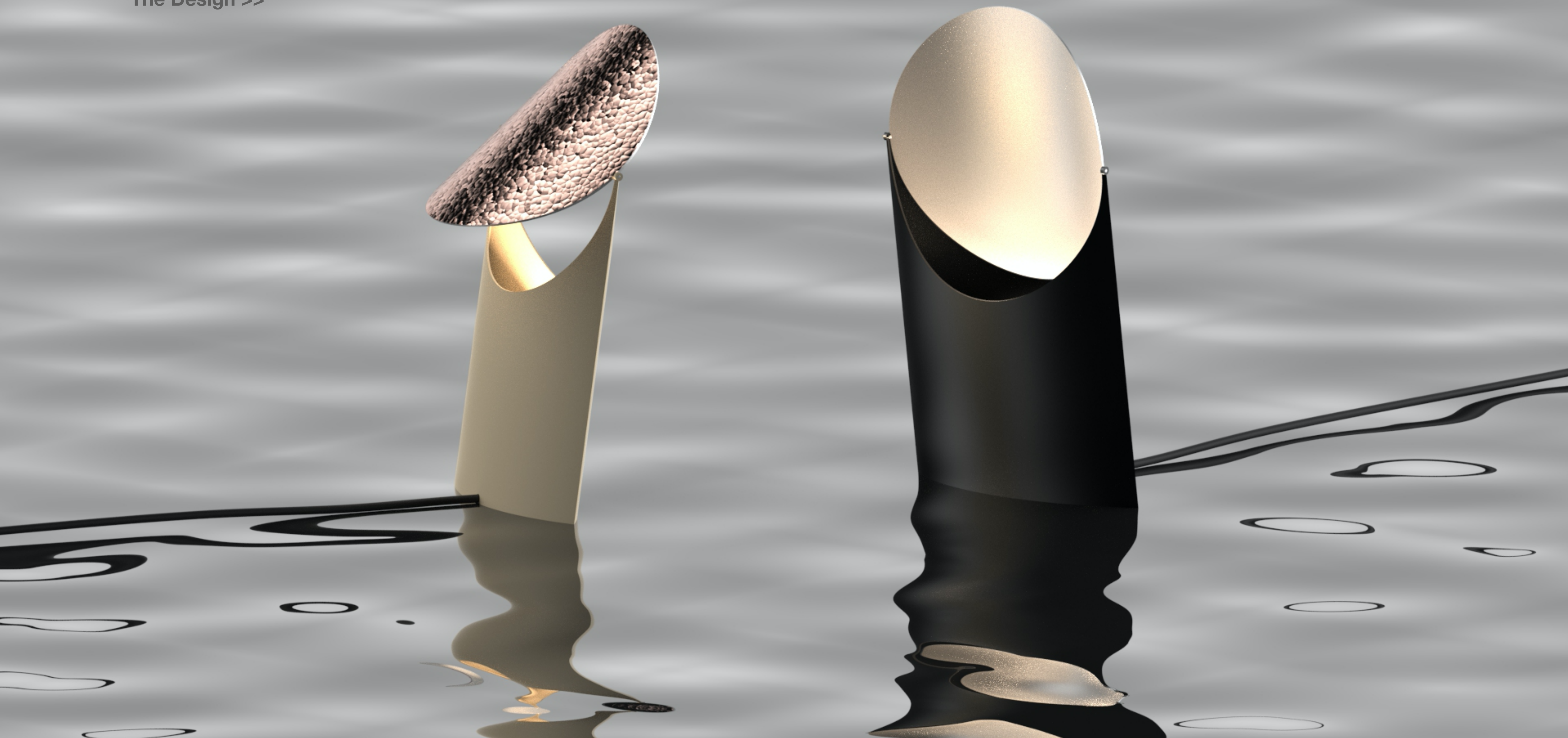

Testings and design process >>

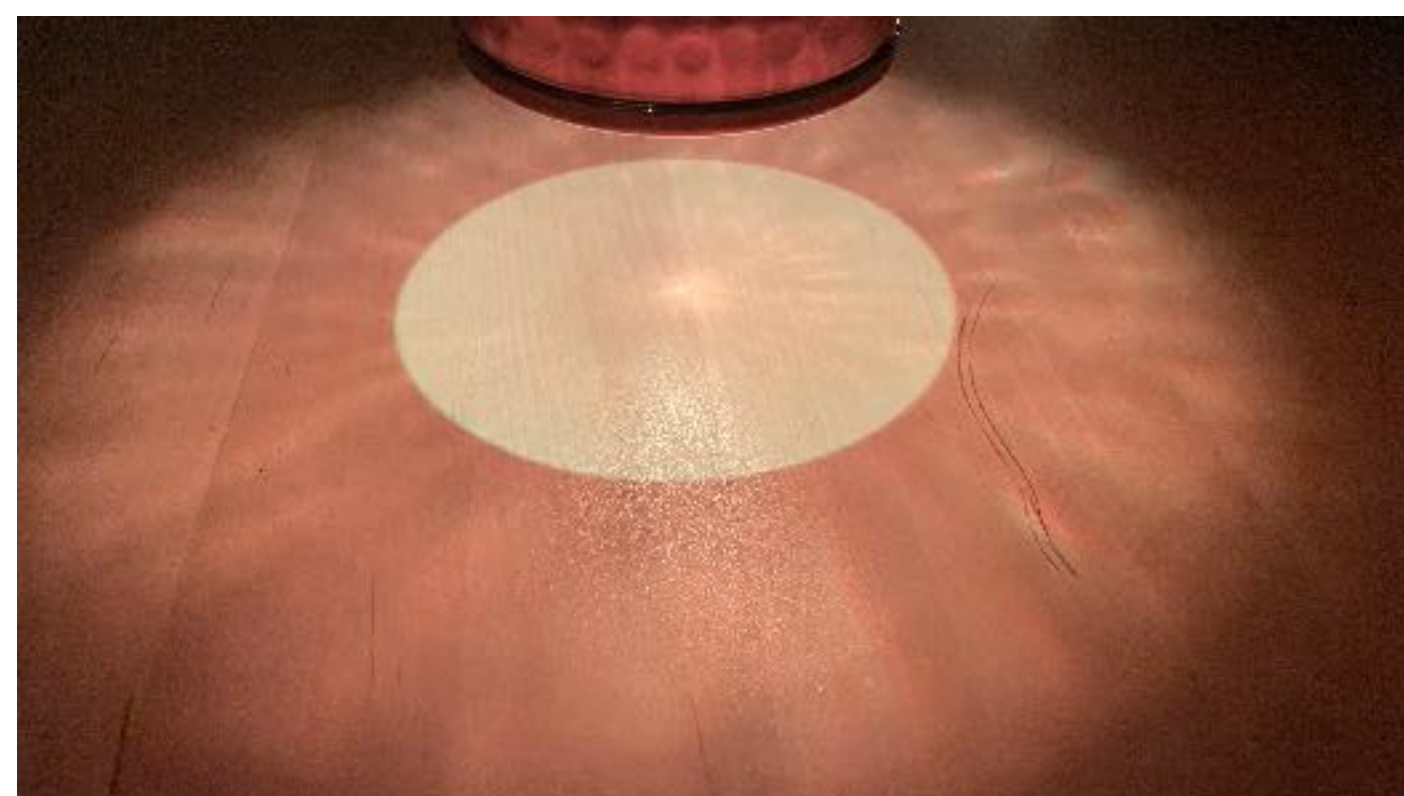
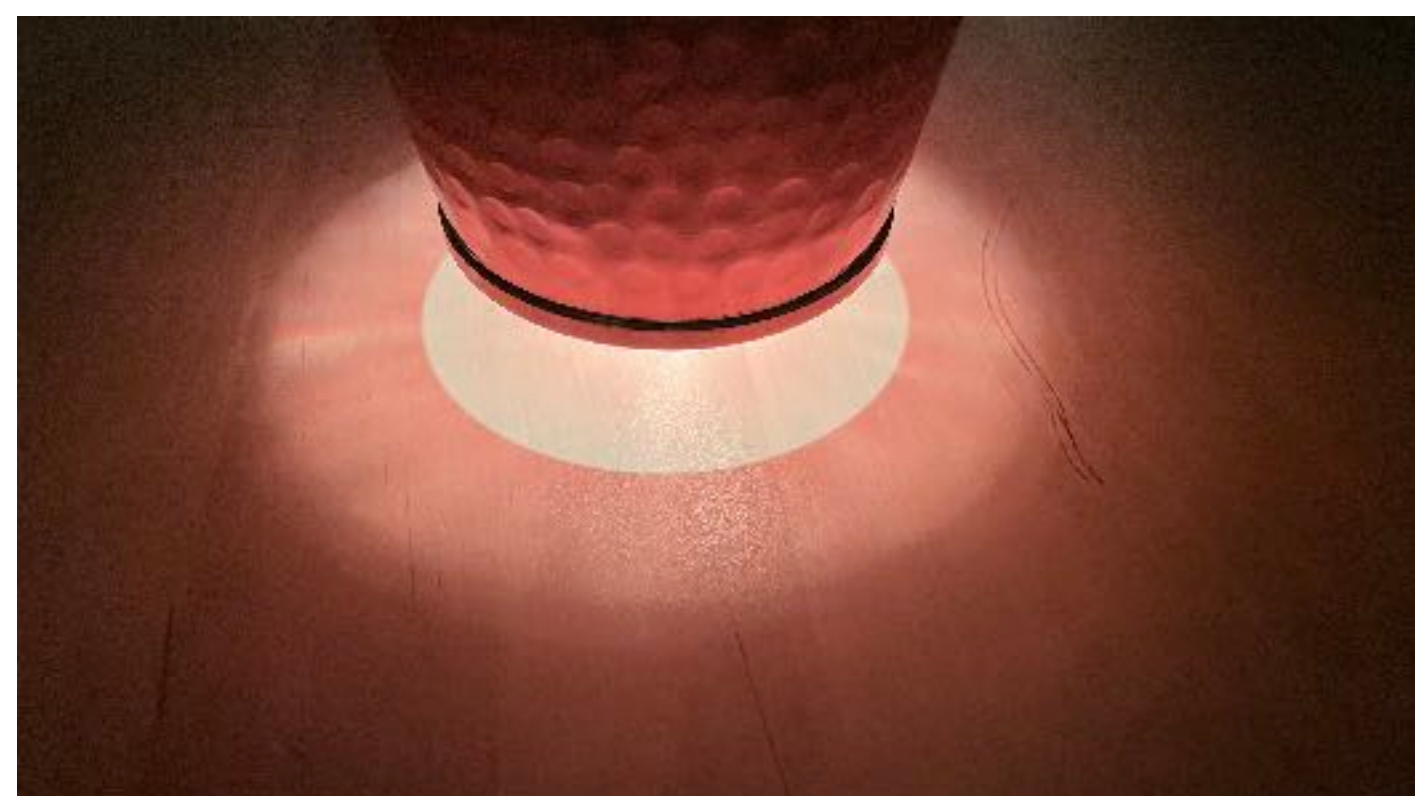
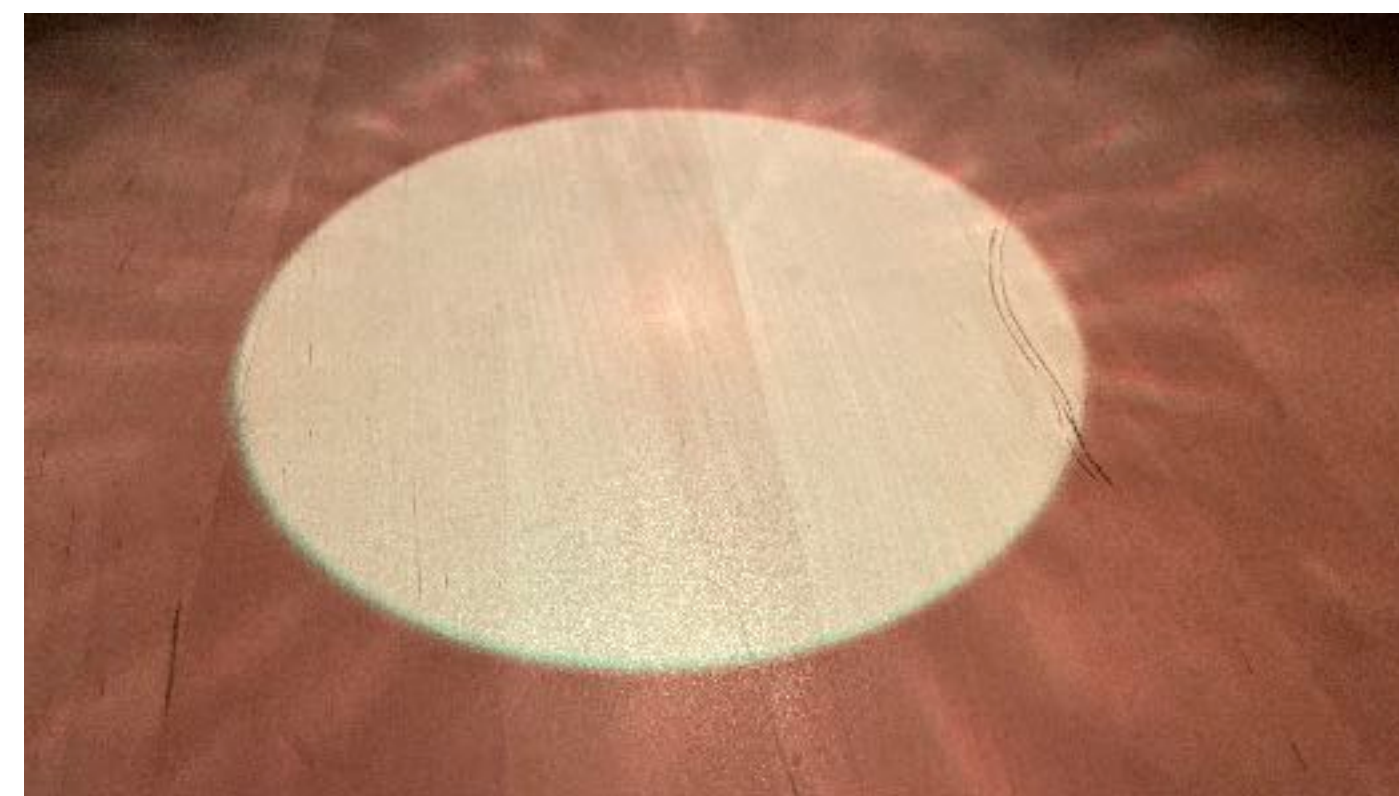

Testings and design process >>



Testings and design process >>



Testings and design process >>

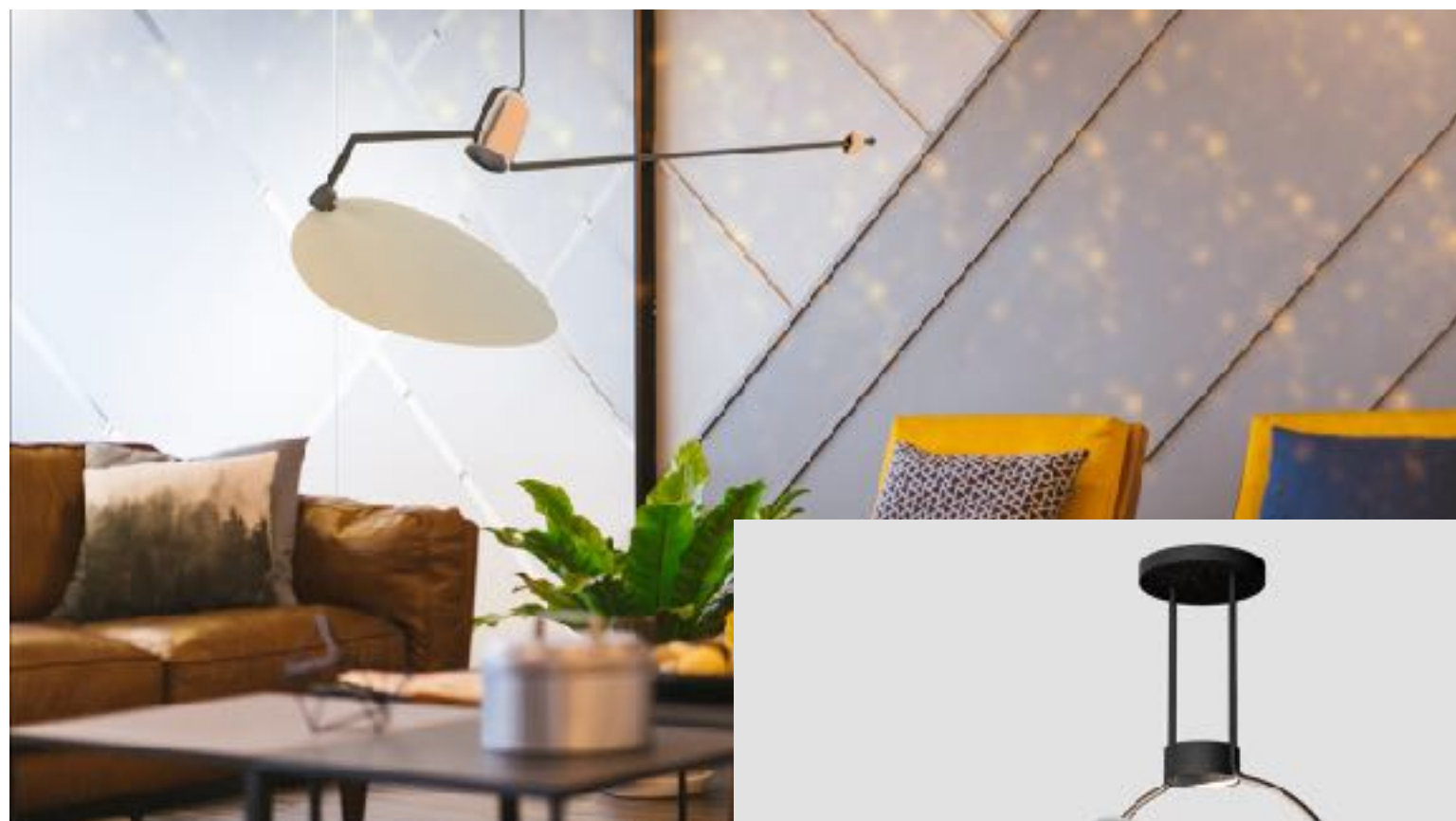

Testings and design process >>

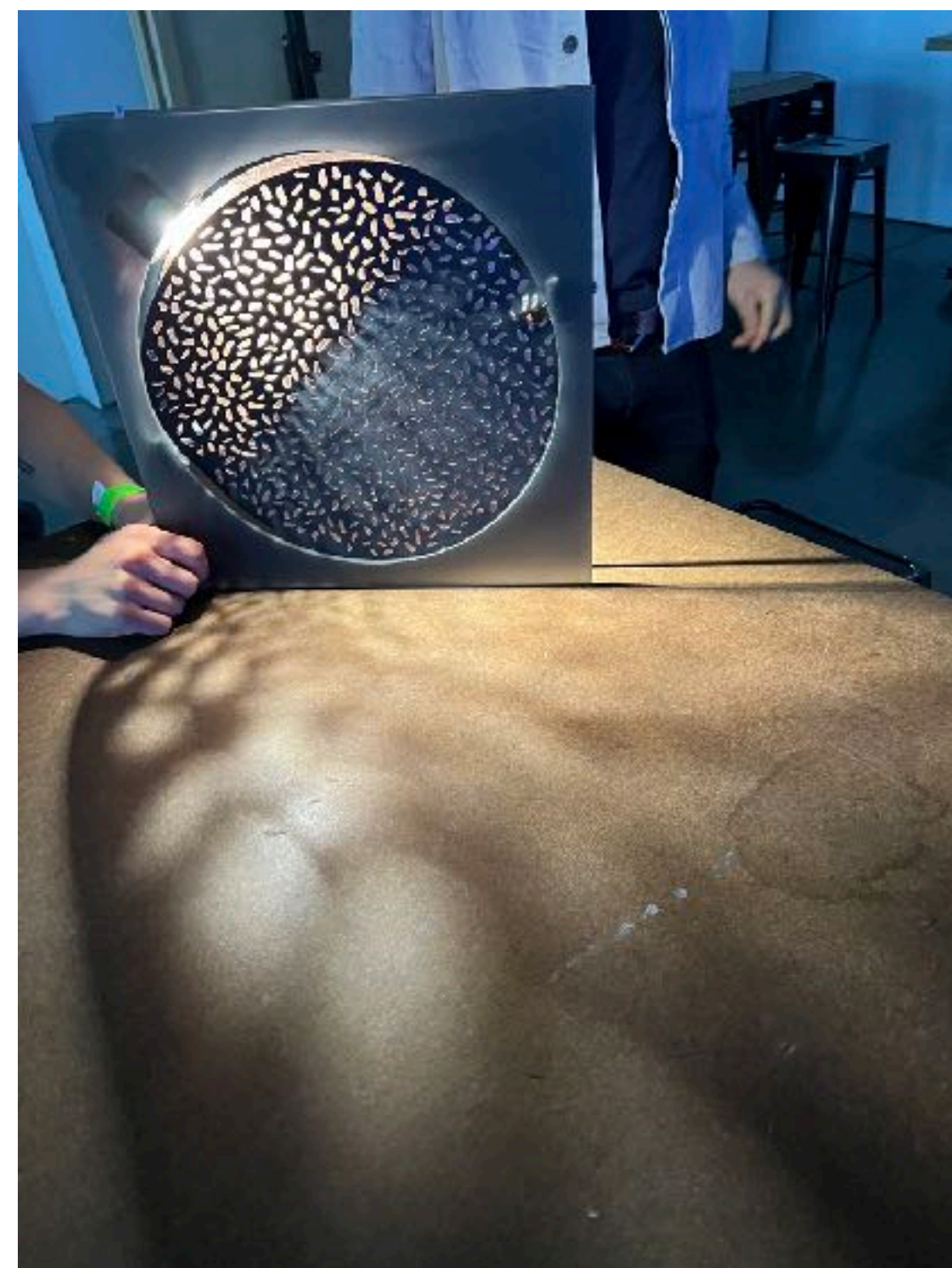
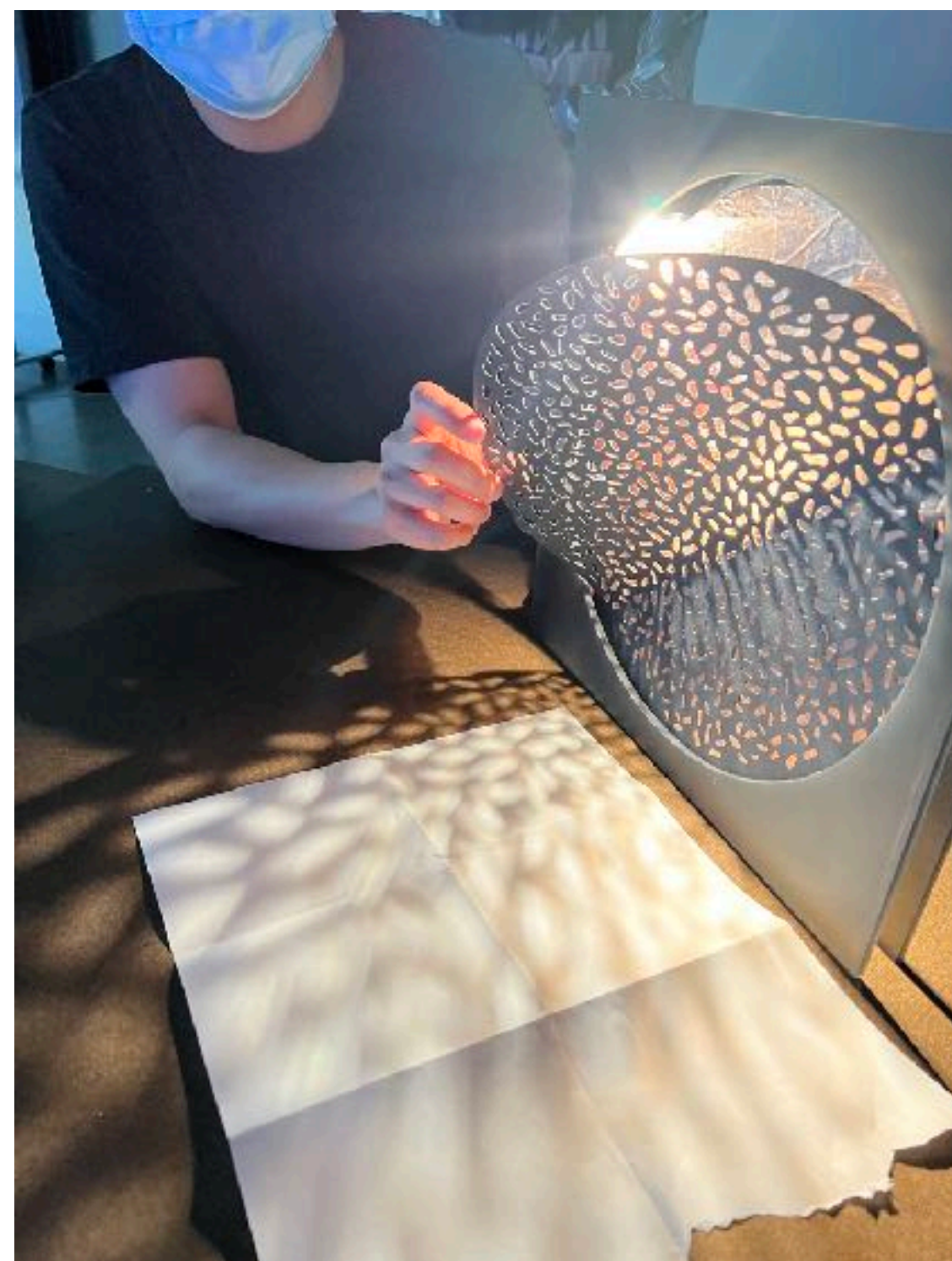



Testings and design process >>

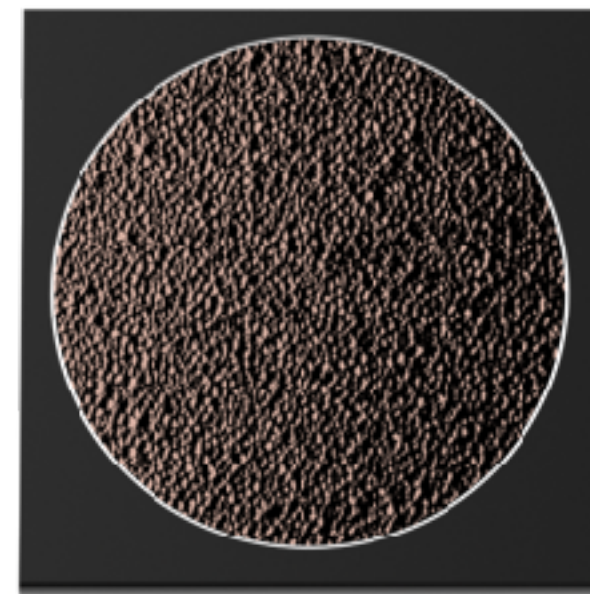
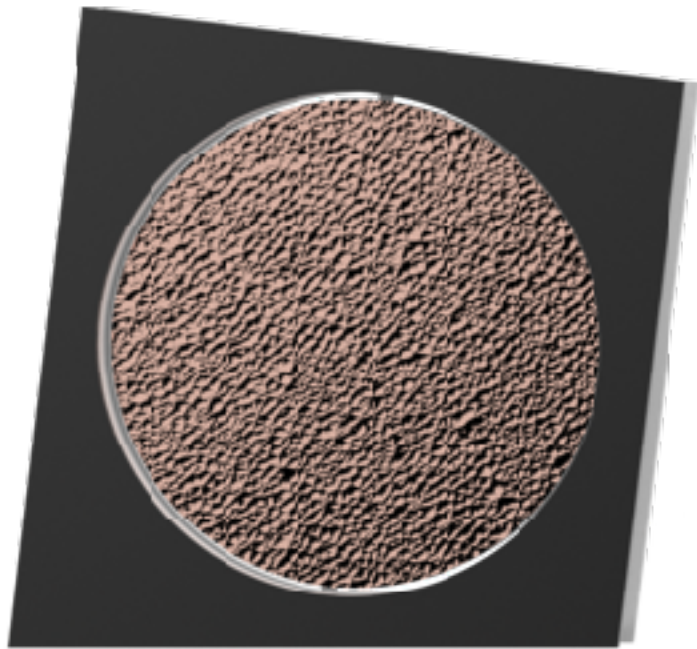
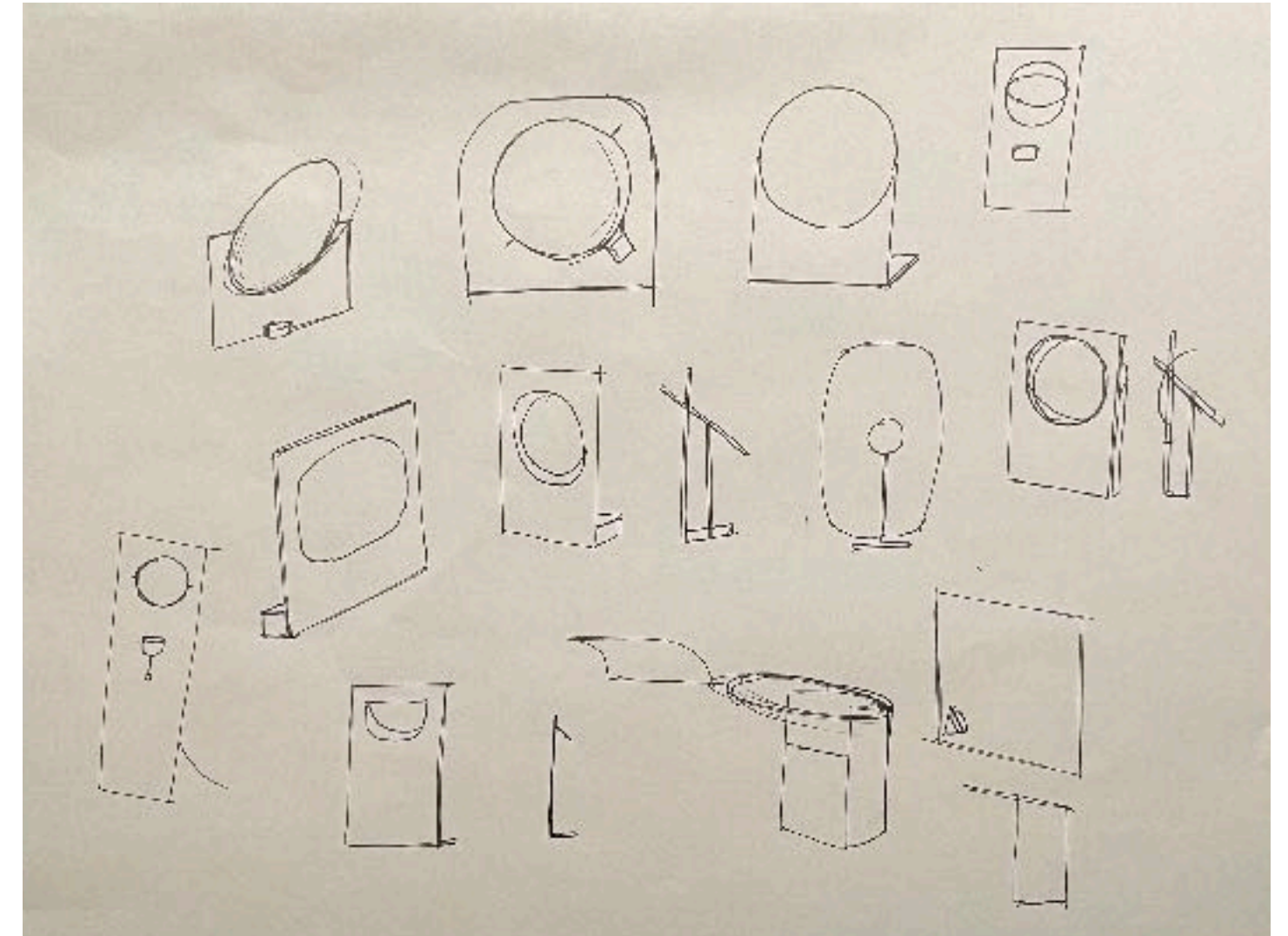
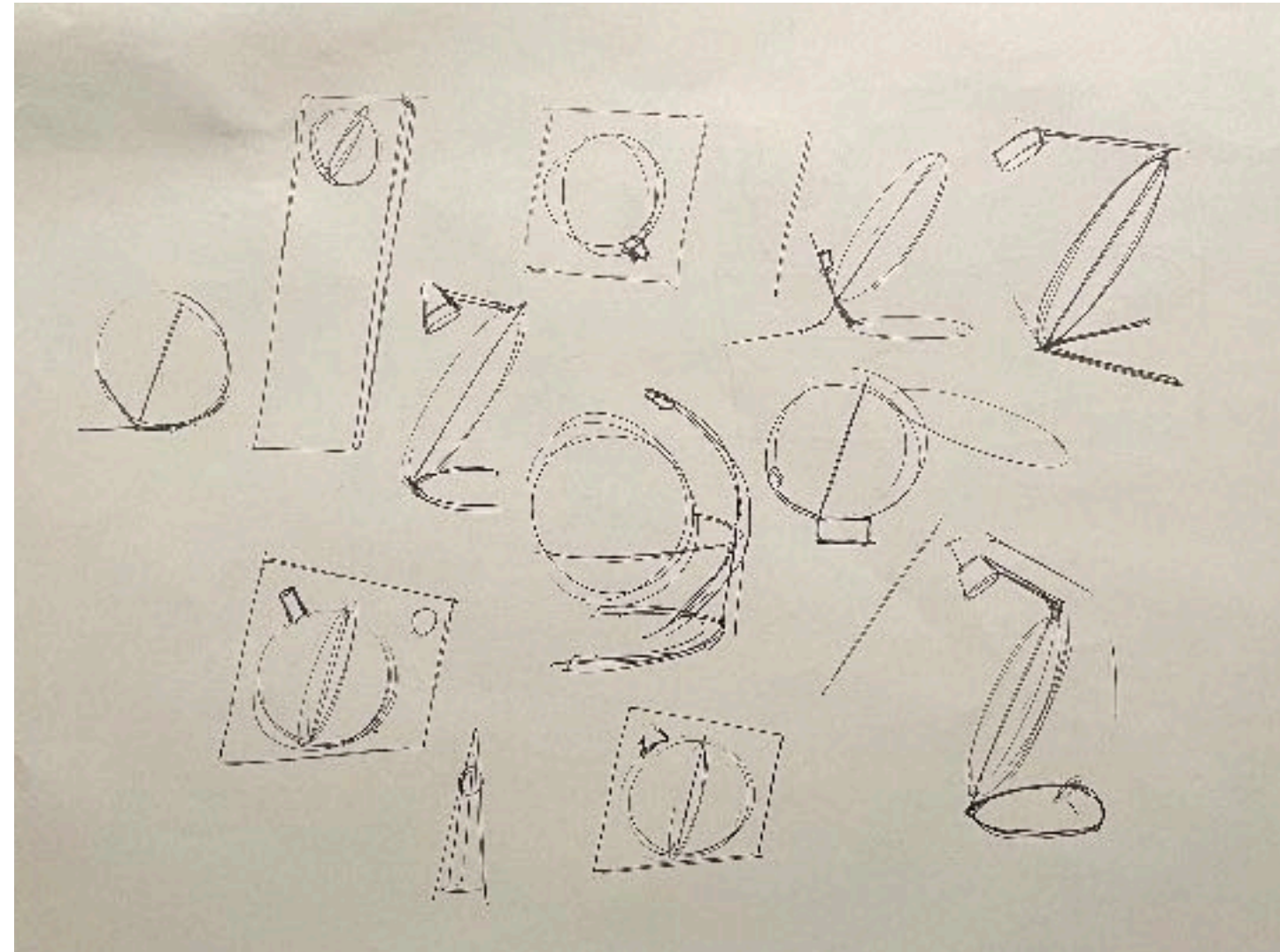
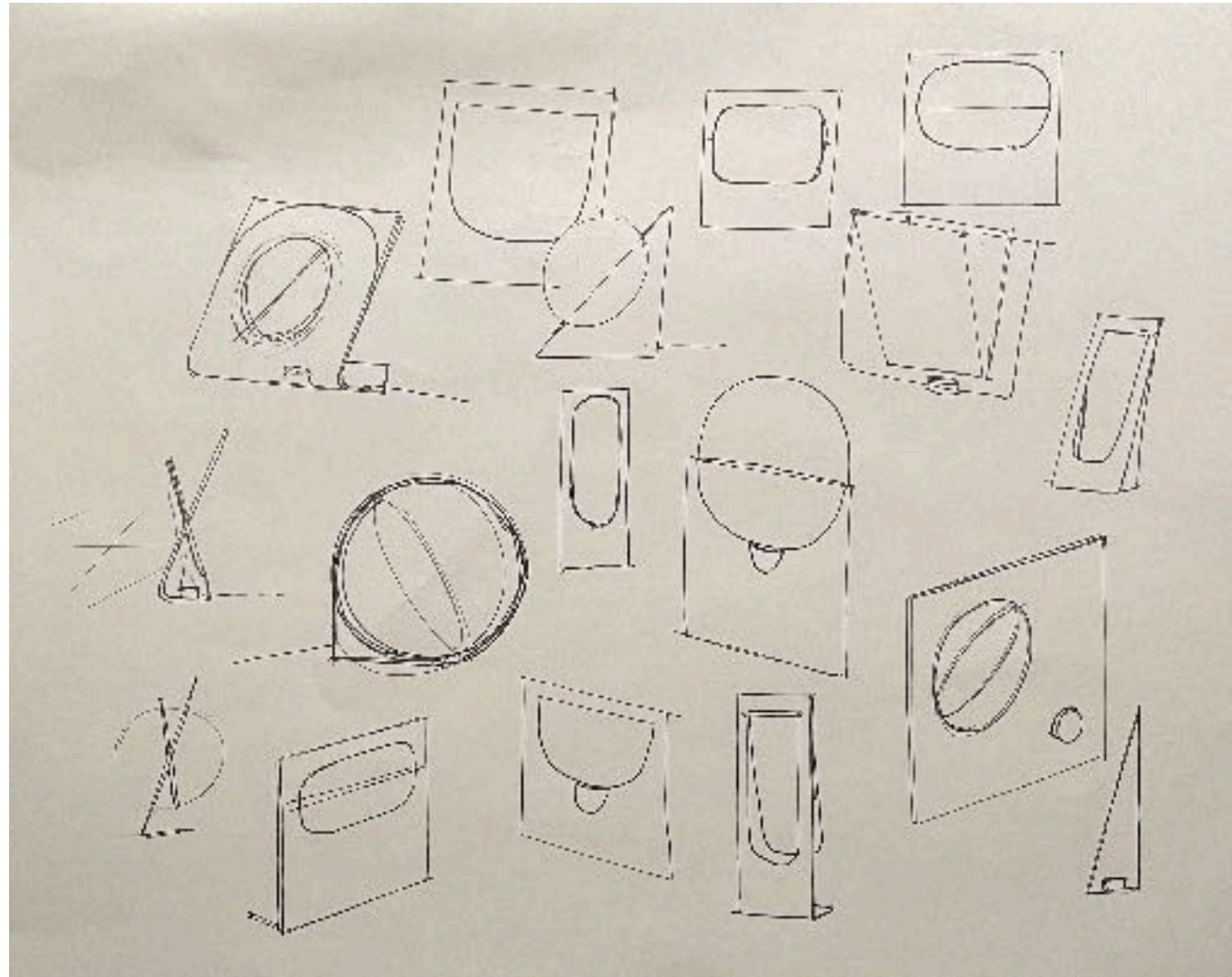

Dimensions >>

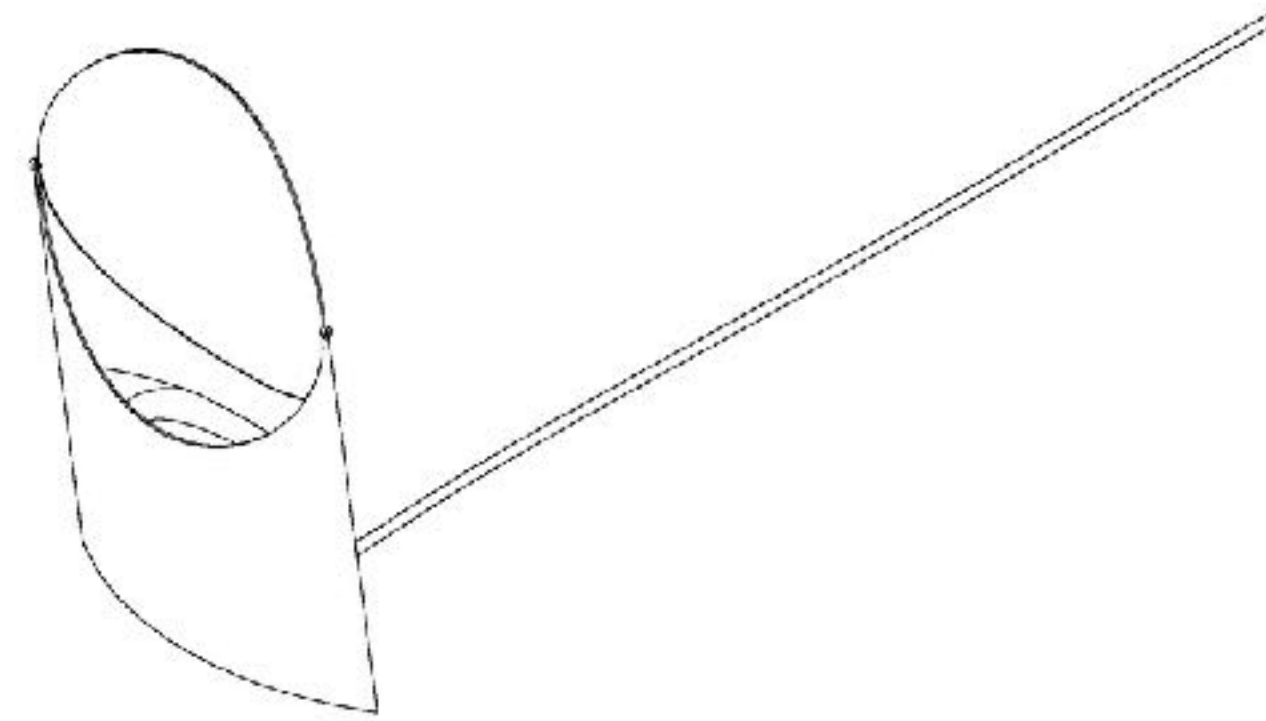
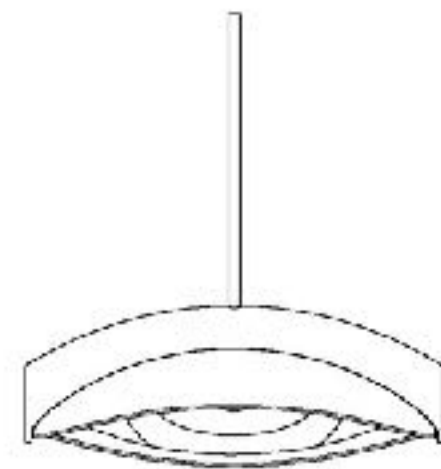
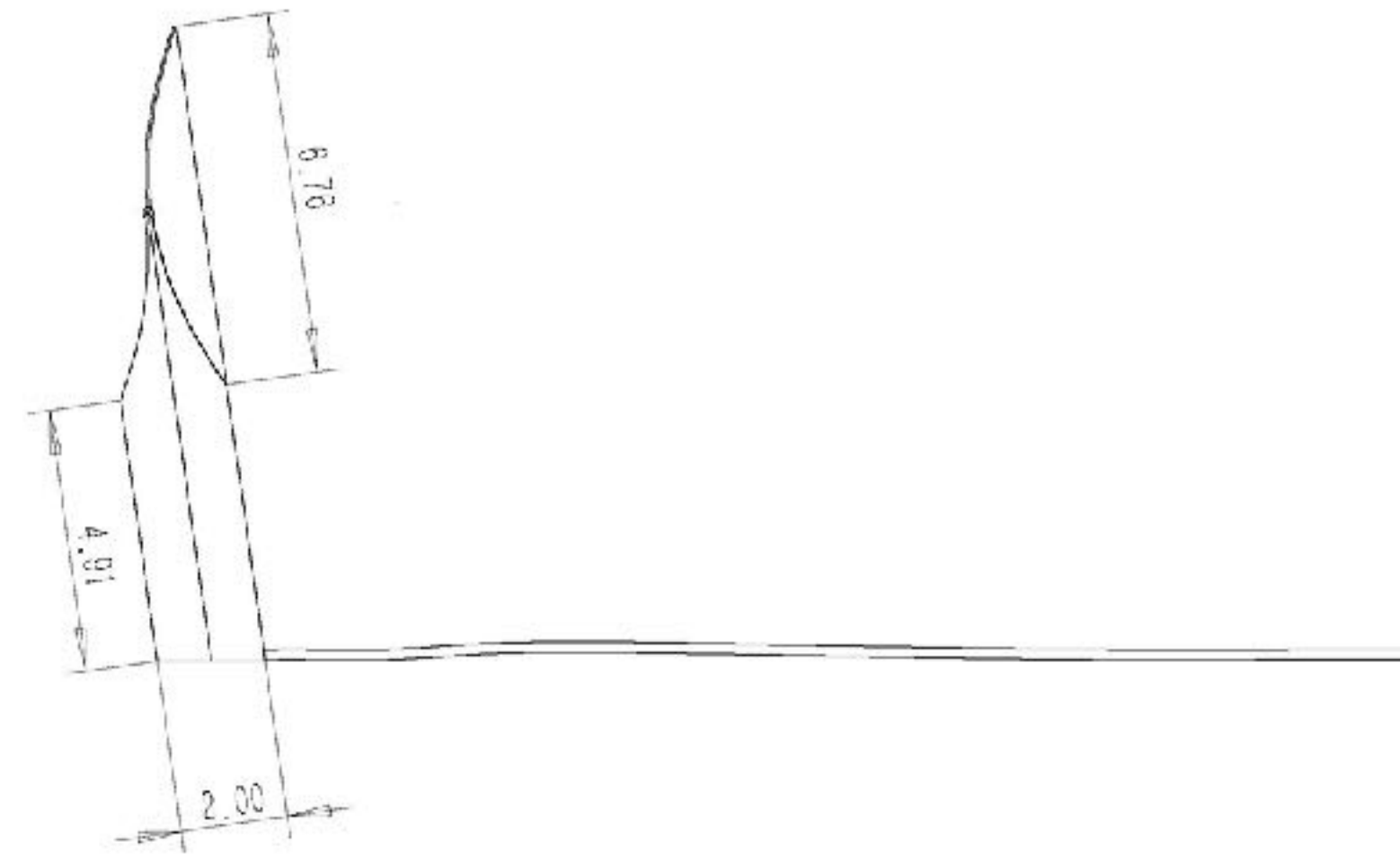
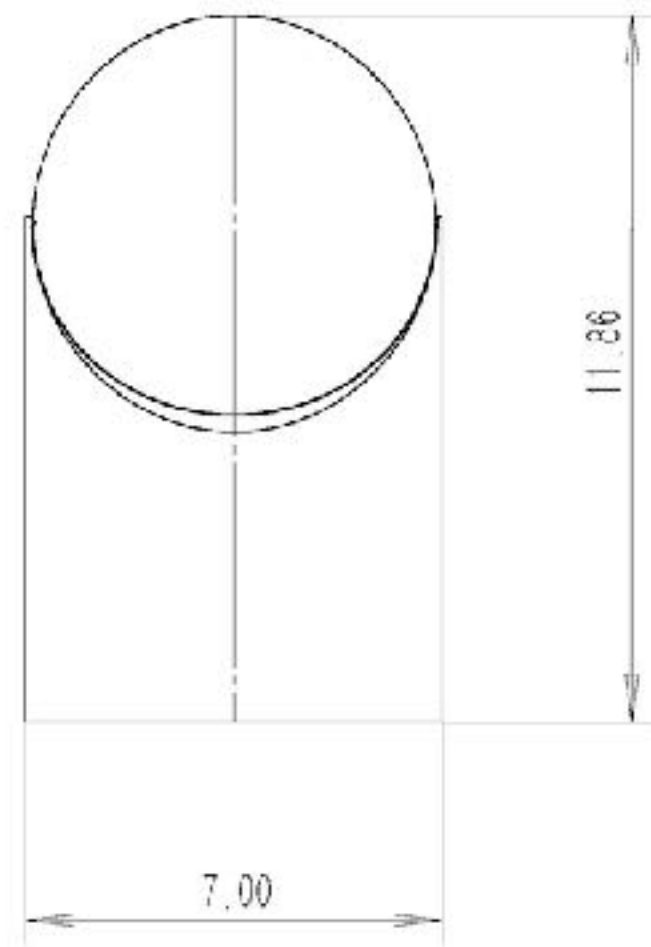

Materials and Manufacturing Process >>

White powder coating



Ripple textured polished copper

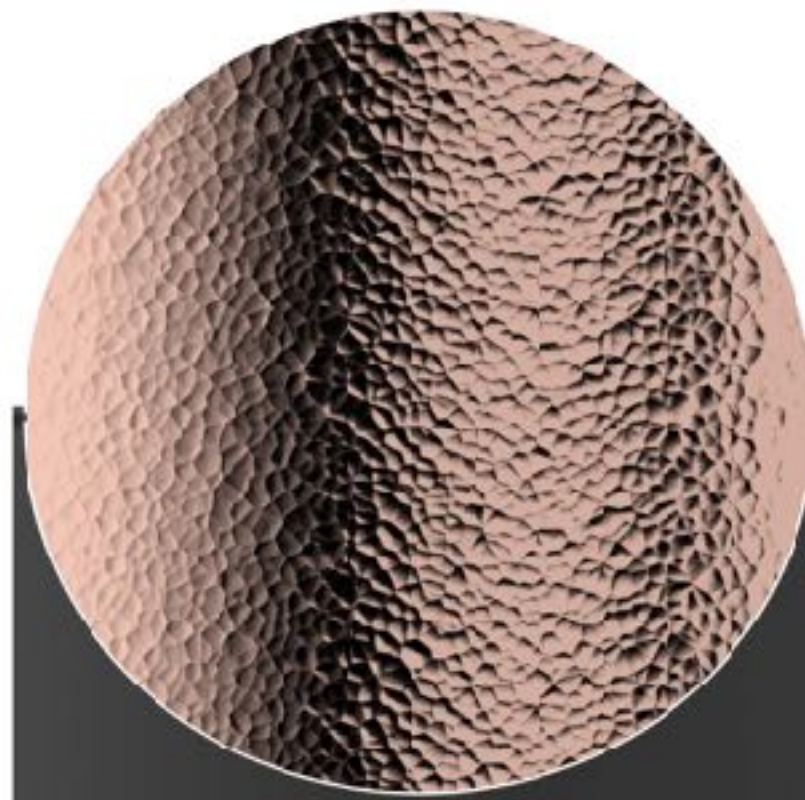

Light source

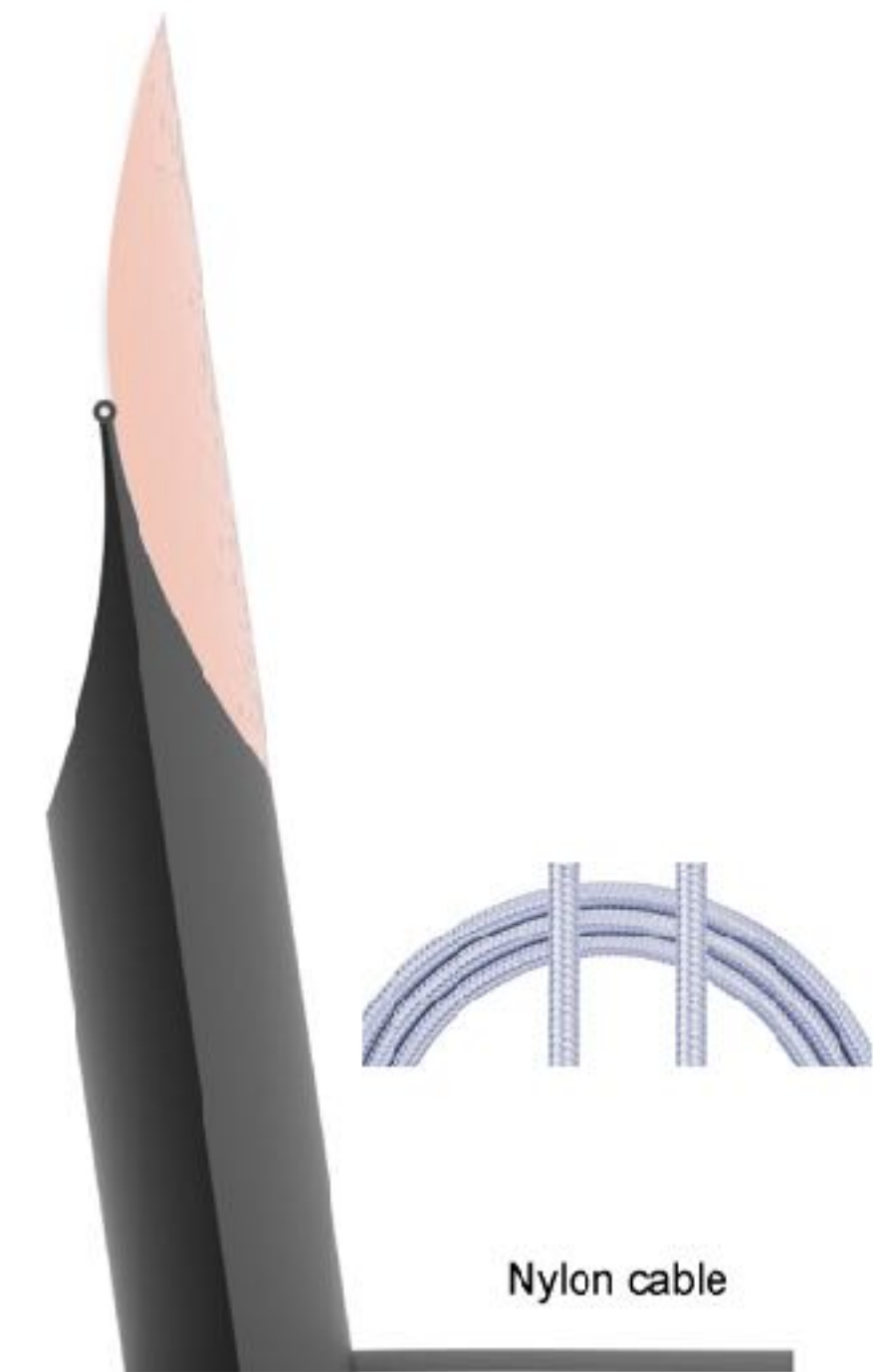

Nylon cable

Color powder coating



Front

Back

Right

Materials and Manufacturing Process >>

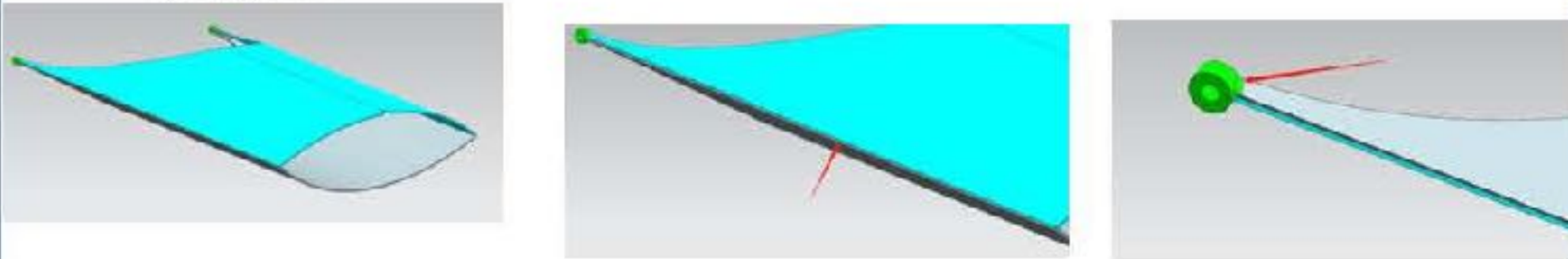
Po#:	Part ID: Fresh Light 14 Body.STEP
1.如图所示，分为3个部分做焊接。（3个颜色）材料需更换为AL5052,采用钣金工艺+焊接。在红色箭头焊缝处焊接。焊接完成后打磨为R角。保证公差为 $\pm 0.8\text{MM}$	
修改后3D	Welding area 焊接细节图
	

Sheet metal, AL5052 Aluminum

Po#:	Part ID: Fresh Light 14 Body.STEP
1.如图所示，分为2个部分进行焊接加工。材料更改为AL5052.钣金+焊接工艺。	
3D	Welding area 焊接细节图
	

Sheet metal, AL5052 Aluminum

Materials and Manufacturing Process >>

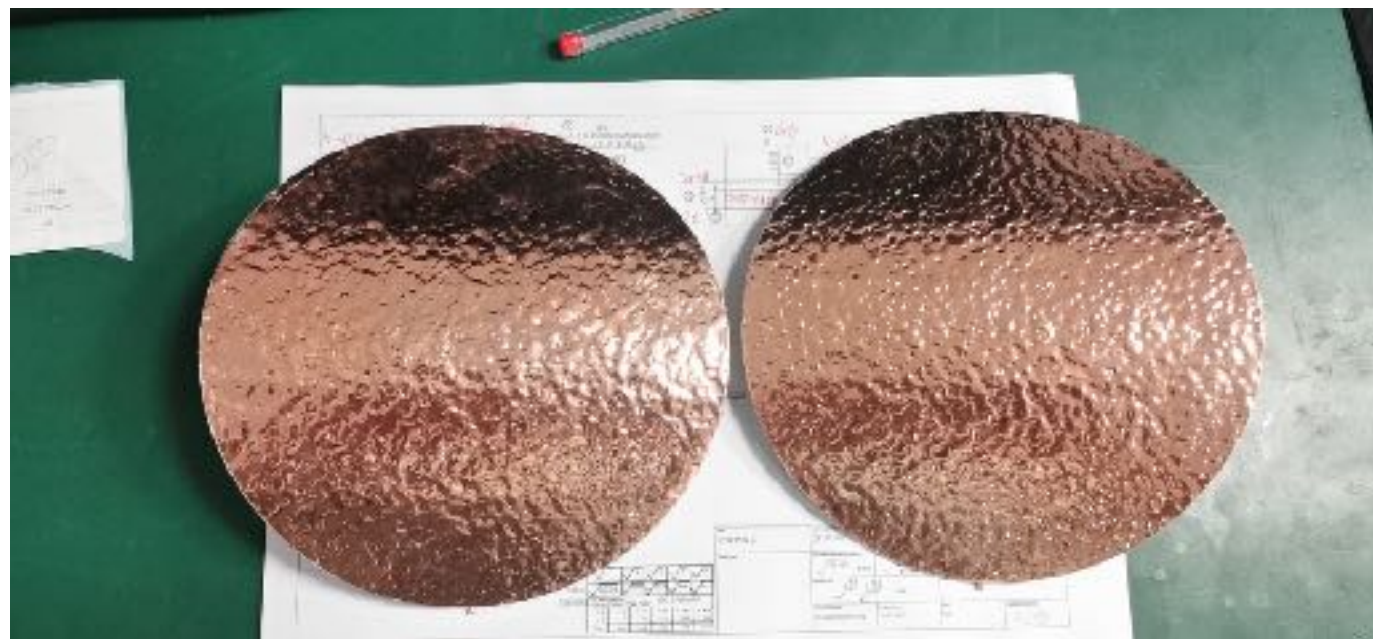
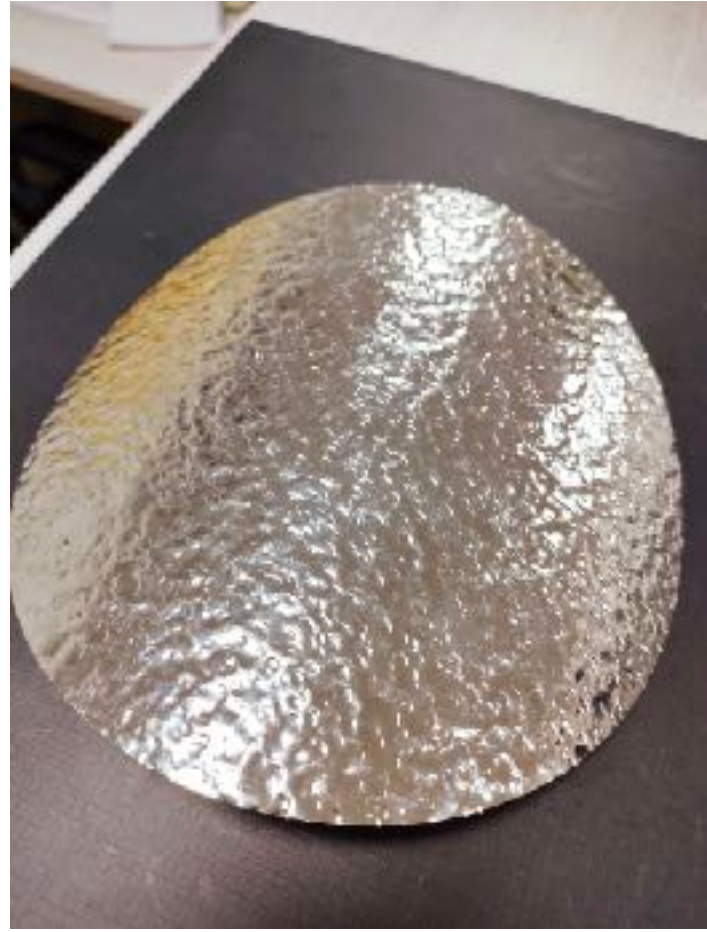







Thank you!